



 **Oxford**
Innovation For Safety

tele  *cron*

telecroatian network
www.telecron.net

**LOWPRO 15/05
ROAD PLATE
INSTALLATION**

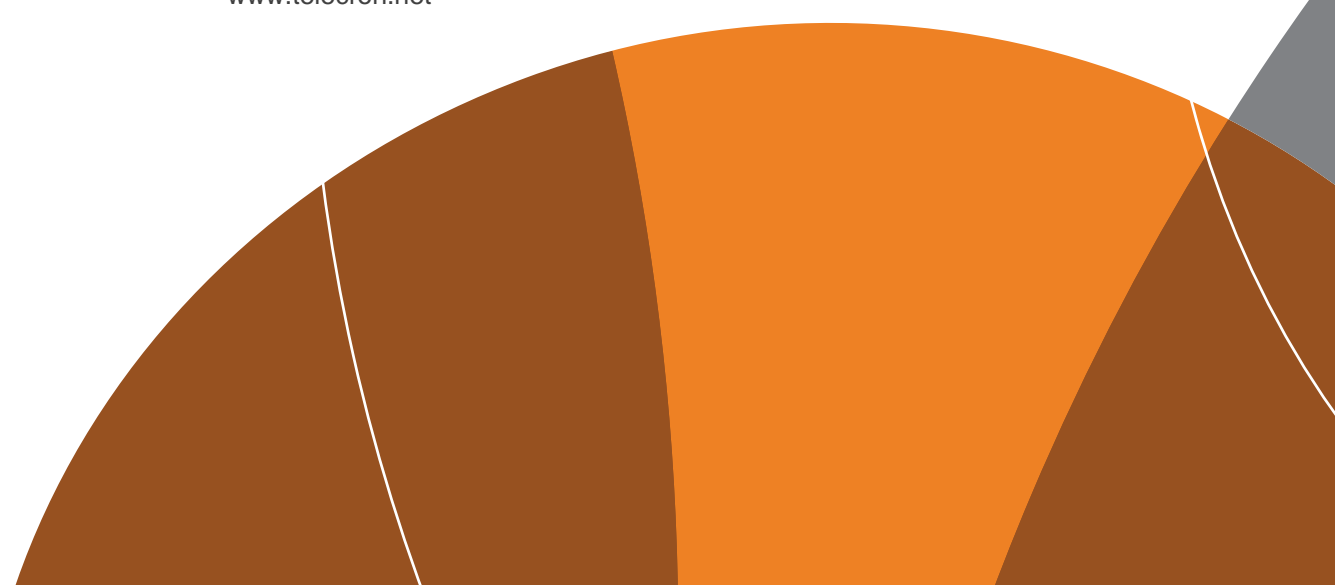

LOWPRO 15/05 ROAD PLATE – DRIVEWAY & PEDESTRIAN TRENCH COVER

The LowPro 15/05 Road Plate is a heavy duty modular system comprising individual units linked together.

The SMC (sheet moulded compound), GRP (glass-reinforced plastic) vehicle road plate trench cover is an alternative to steel plates.

The anti-slip surface provides secure pedestrian access and is ideal for use in residential areas.

The integral Flexi-edge of the LowPro Road Plate is designed to minimise road noise.

Easy to use and transport, this long-lasting and robust composite trench cover can take up to a 44 tonnes vehicle over a 700mm trench. The LowPro Road Plate is used in many worksite applications, including work-site construction, excavation and streetworks. The LowPro Road Plate should be bolted down for carriageway use.

PRE-INSTALLATION SAFETY GUIDELINES & MAINTENANCE

- Each LowPro weighs approx. 42 kg and should be lifted by 2 people.
- Confirm all parts & components are securely attached and in working order.

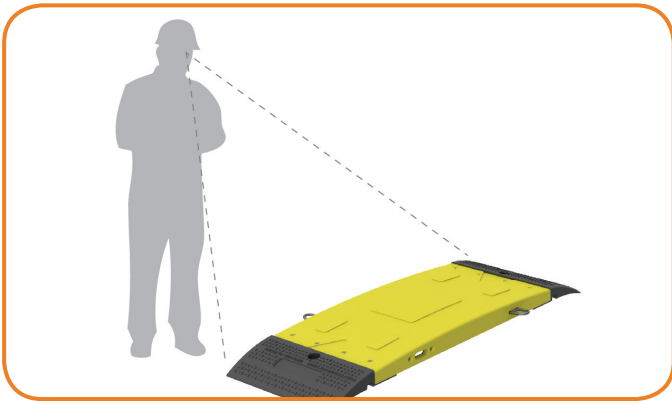

1. Check top surface of LowPro Road Plate for signs of damage.
2. Ensure all drop pins are moving freely.

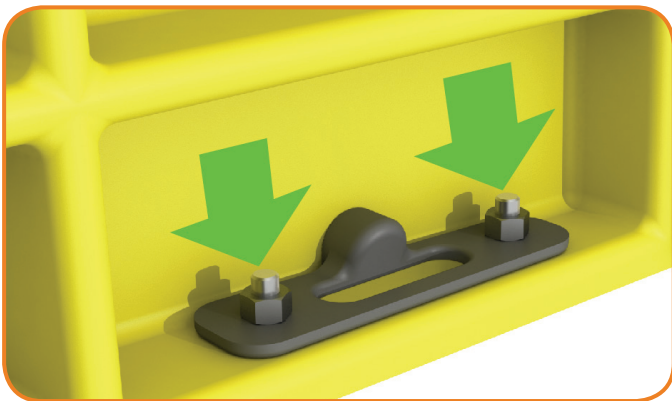

3. Check linking plate bolts are tight underneath.



INSTALLATION KIT

- SDS hammer drill
- SDS 22mm drill bit
- Torque wrench
- 4 x M16 bolts (per LowPro section)

INSTALLATION INSTRUCTIONS

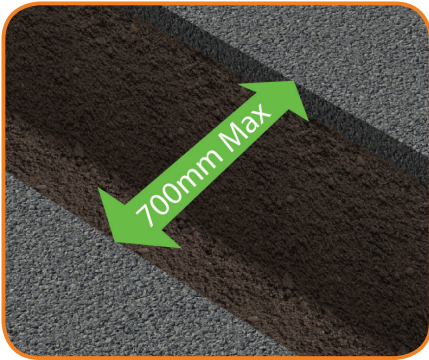

1. Ensure max trench width less than 700mm. Assess trench stability prior to install.

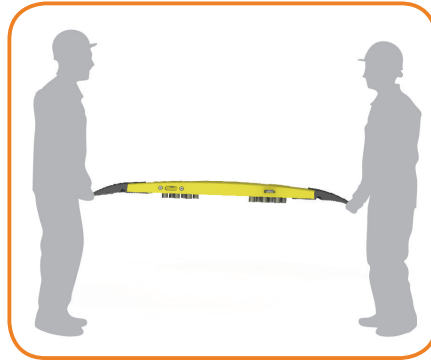

2. 2 person lift at all times.

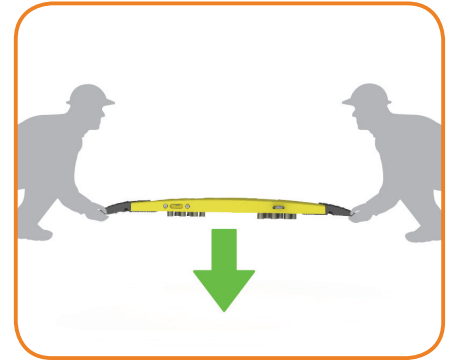

3. Lower into position.

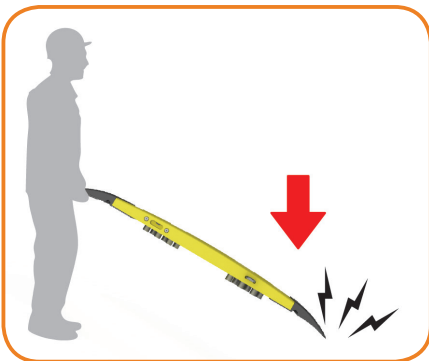

4. Do not throw or drop on to edge.

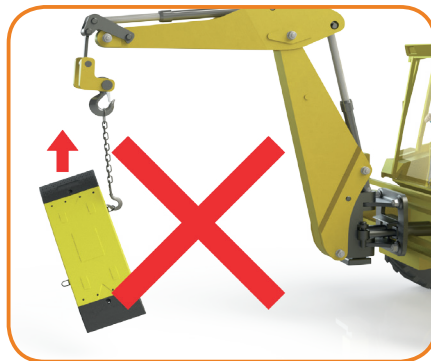

5. Do not lift using male connector.

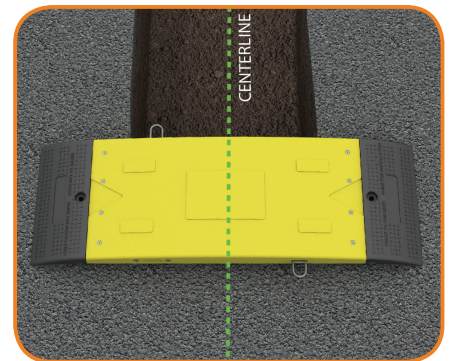

6. Place first inner LowPro section centrally over the trench, using centreline mark as a guide.

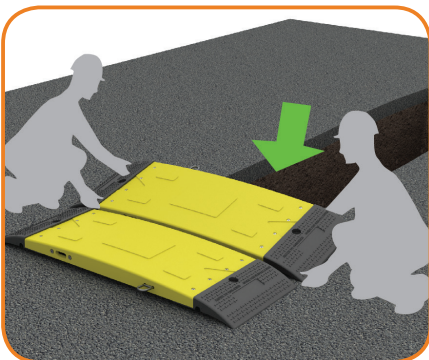

7. Lower next plate at an angle so the connectors fit into the slots.

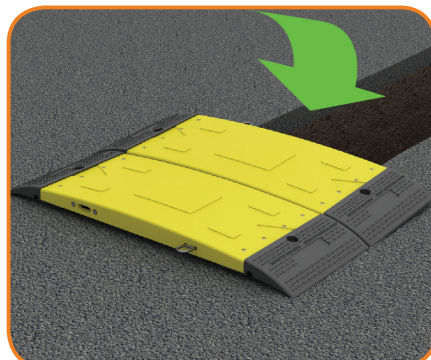

8. When the connectors are in the slots carefully lower the plate.

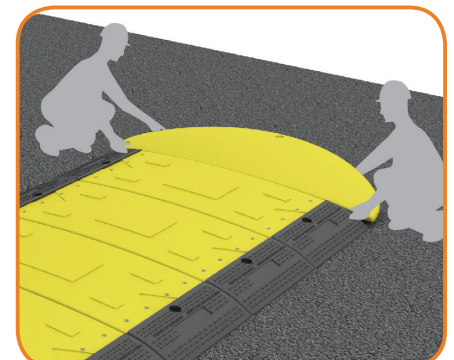

9. Repeat previous step until entire trench is covered by inner LowPro sections.

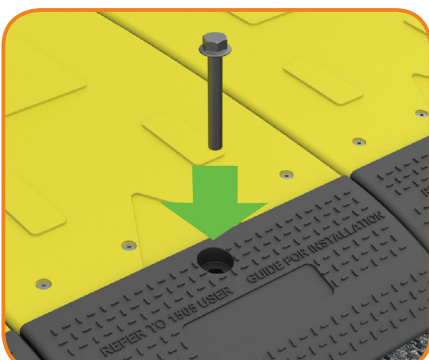

10. Use M16 bolt to fix the LowPro to the road.

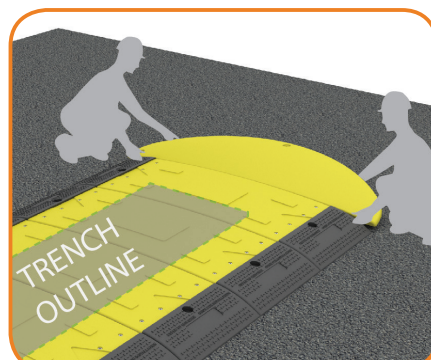

11. If required, connect the LowPro Road Plate end sections.



12. End section is not load bearing. Do not place end section over trench.

DISMANTLING INSTRUCTIONS

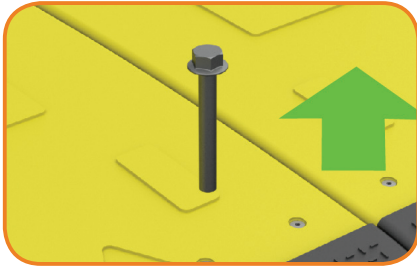

1. Remove bolts that were used to anchor the LowPro to the road.

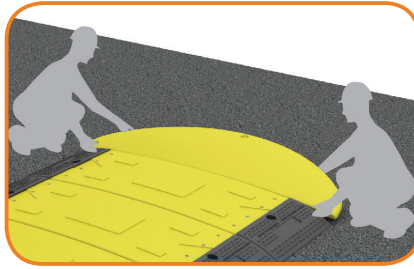

2. Starting from the end sections, carefully lift the plate at an angle and slide outwards to remove plate.

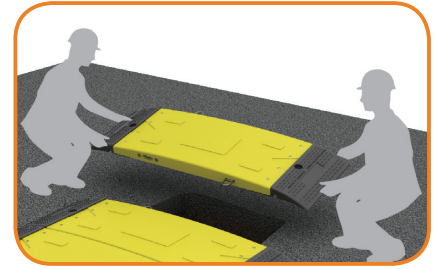

3. Repeat step 2 to remove each section at a time.

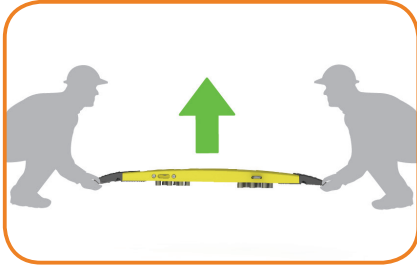

4. Lift by hand.

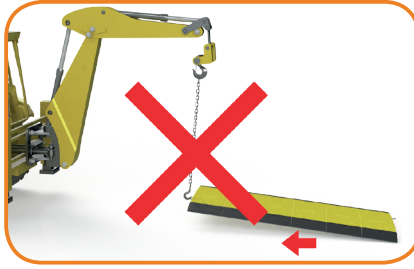

5. Do not use the male connector as a dragging point.



6. Do not use tools to aid lifting.



7. Clean after use.

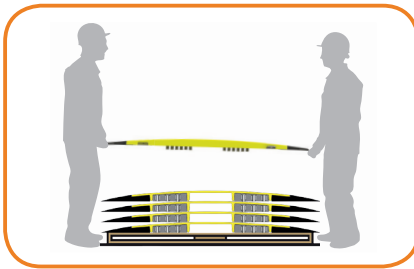

8. Store on a pallet.

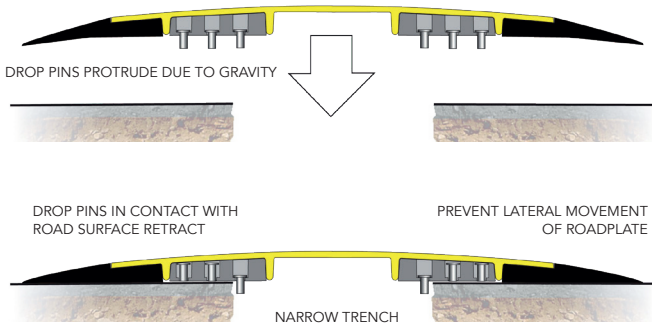
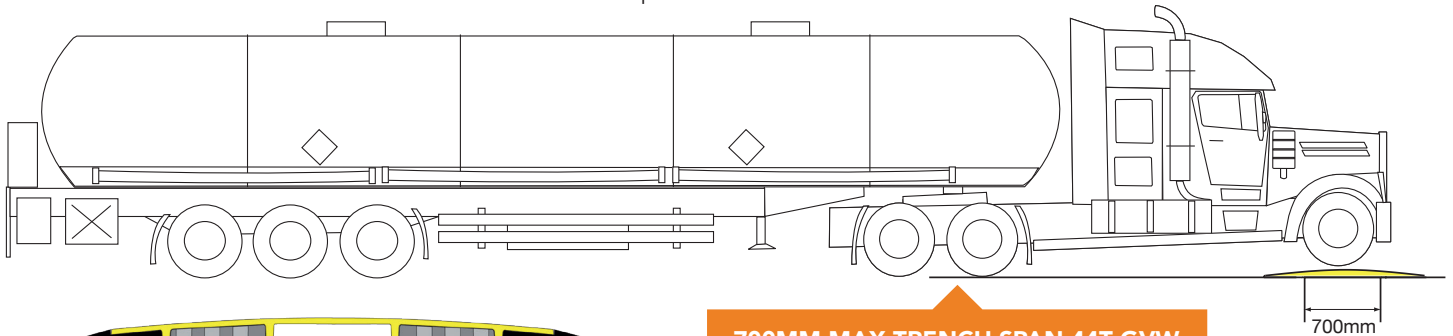

INTEGRAL DROP PINS INCREASE PRODUCT STABILITY. ALWAYS CHECK THE DROP PINS ARE IN GOOD WORKING ORDER.

700MM MAX TRENCH SPAN 44T GVW

Oxford
Innovation For Safety

Scan QR code for installation guide:



+44 (0) 1608 678888
sales@oxfordplastics.com
www.oxfordplastics.com
www.oxfordplasticsusa.com



Installation guides also available at www.oxfordplastics.com

Find this label on Oxford LowPro Road Plates.
Scan the QR code for product installation guides.